



FOX

38

TUNING GUIDE



SAG SETTING

To achieve the best performance from your FOX suspension, adjust the air pressure to attain your proper sag setting. Sag is the amount your suspension compresses under your weight and riding gear. Sag range should be set to 15–20% of total fork travel.

Make sure to set sag with the compression lever in the OPEN mode, see page 5.

Watch the sag setup video at ridefox.com/sagsetup

| Suggested Sag Measurements | | |
|----------------------------|----------------|-----------------|
| Travel | 15% sag (Firm) | 20% sag (Plush) |
| 150 mm (5.9 in) | 22 mm (.9 in) | 30 mm (1.2 in) |
| 160 mm (6.3 in) | 24 mm (1.0 in) | 32 mm (1.3 in) |
| 170 mm (6.7 in) | 26 mm (1.0 in) | 34 mm (1.3 in) |
| 180 mm (7 in) | 27 mm (1.0 in) | 36 mm (1.4 in) |

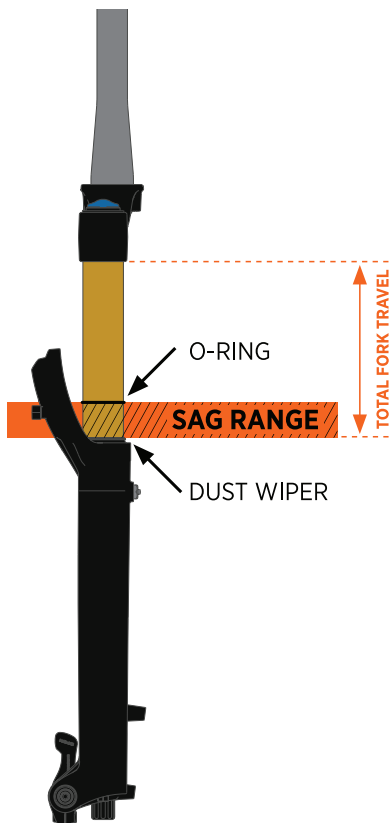



The recommended settings in this tuning guide are designed to be a **starting point**, in order to get you out on your first ride in as few steps as possible. Consult your bike manufacturer's instructions for setup recommendations.

As you ride and get used to your new fork, adjust your settings as needed. Detailed information and videos can be found in the online owner's manual.

| Suggested Starting Points for Setting Sag | | |
|---|--------------------|----------------------|
| Rider Weight (lbs) | Rider Weight (kgs) | FLOAT Pressure (psi) |
| 120-130 | 54-59 | 72 |
| 130-140 | 59-64 | 76 |
| 140-150 | 64-68 | 80 |
| 150-160 | 68-73 | 84 |
| 160-170 | 73-77 | 89 |
| 170-180 | 77-82 | 93 |
| 180-190 | 82-86 | 97 |
| 190-200 | 86-91 | 102 |
| 200-210 | 91-95 | 106 |
| 210-220 | 95-100 | 110 |
| 220-230 | 100-104 | 114 |
| 230-240 | 104-109 | 119 |
| 240-250 | 109-113 | 123 |



Do not exceed maximum air pressure:
38 FLOAT maximum air pressure is **140 psi**.



REBOUND ADJUSTMENT

The rebound adjustment is dependent on the air pressure setting. For example, higher air pressures require slower rebound settings. Use your air pressure to find your rebound setting.

Turn your rebound knob to the closed position, clockwise until it stops. Then turn it counter-clockwise to the number of clicks shown in the table below.

REBOUND

Rebound controls the rate of speed at which the fork extends after compressing.



| Rider Weight (lbs) | Rider Weight (kgs) | 38 FIT4 | 38 GRIP | 38 GRIP2 | |
|--------------------|--------------------|---------|---------|----------|-----|
| | | | | LSR | HSR |
| 120-130 | 54-59 | 14 | 13 | 9 | 8 |
| 130-140 | 59-64 | 13 | 12 | 8 | 7 |
| 140-150 | 64-68 | 12 | 11 | 7 | 6 |
| 150-160 | 68-73 | 11 | 10 | 7 | 6 |
| 160-170 | 73-77 | 9 | 9 | 6 | 5 |
| 170-180 | 77-82 | 8 | 8 | 6 | 5 |
| 180-190 | 82-86 | 7 | 7 | 5 | 4 |
| 190-200 | 86-91 | 6 | 6 | 4 | 3 |
| 200-210 | 91-95 | 5 | 5 | 4 | 3 |
| 210-220 | 95-100 | 4 | 4 | 3 | 2 |
| 220-230 | 100-104 | 3 | 3 | 2 | 1 |
| 230-240 | 104-109 | 2 | 2 | 2 | 1 |
| 240-250 | 109-113 | 1 | 1 | 1 | 0 |

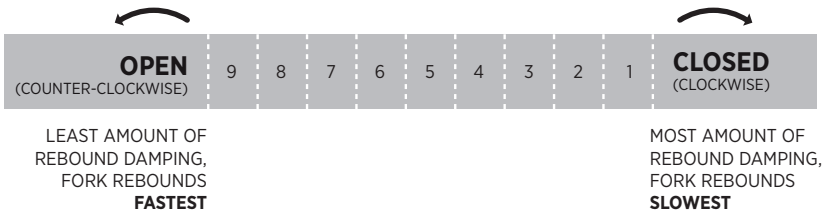

COMPRESSION ADJUSTMENTS

FIT4 3-POSITION LEVER

Begin with the 3-position lever in the OPEN mode.

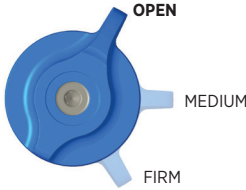

The **3-position lever** is useful to make on-the-fly adjustments to control fork performance under significant changes in terrain, and is intended to be adjusted throughout the ride.

Use the OPEN mode during rough descending, the MEDIUM mode for undulating terrain, and the FIRM mode for smooth climbing.

*OPEN MODE ADJUST

Set the OPEN mode adjust to 18 clicks out (counter-clockwise until it stops).

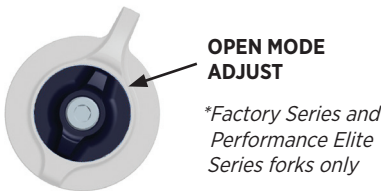

***OPEN mode adjust** is useful to control fork performance under rider weight shifts, G-outs, and slow inputs.

OPEN mode adjust provides 22 additional fine tuning adjustments for the OPEN mode.

Setting 18 will have a more plush feel and setting 1 will have a firmer feel.



GRIP COMPRESSION ADJUST

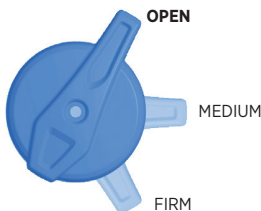

The **3-Position Micro Adjust** lever is useful to make on-the-fly adjustments to control fork performance. Use the positions between the OPEN, MEDIUM, and FIRM modes to fine-tune your compression damping.

The **2-Position Sweep Adjust (36 Rhythm forks only)** lever is useful to make on-the-fly adjustments to control fork performance. Use the positions between OPEN and FIRM modes to fine-tune your compression damping.



FACTORY SERIES GRIP2 COMPRESSION ADJUSTERS

Use this diagram as a starting point for your compression adjusters.

Turn your compression adjusters to the closed position (full clockwise) until they stop. Then back them out (counter-clockwise) to the number of clicks shown below.



High-speed compression adjustment is useful to control fork performance during bigger hits, landings, and square-edged bumps.



Low-speed compression adjustment is useful to control fork performance during rider weight shifts, G-outs, and other slow inputs.

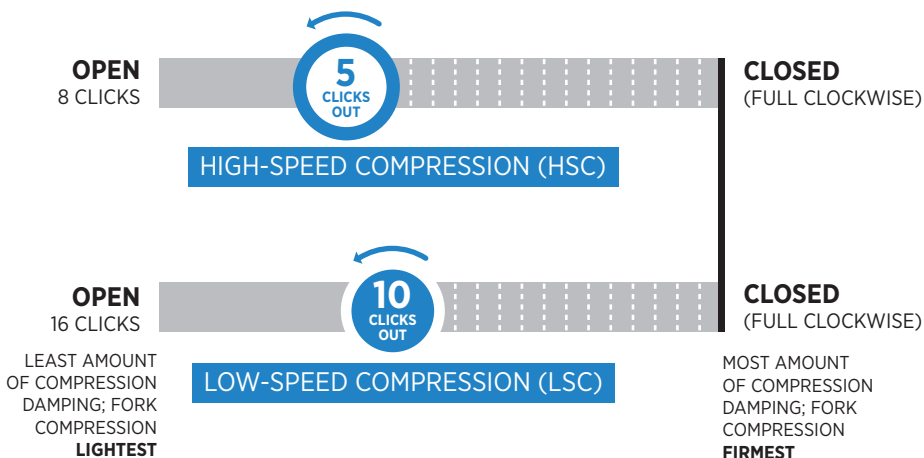

15 MM QUICK RELEASE INSTALLATION

1. Loosen the pinch bolt, then install the front wheel into the fork dropouts. Slide the axle through the drive side dropout and hub.
2. Open the axle lever and pinch bolt.
3. Turn the axle clockwise 5-6 complete turns into the axle nut.
4. Close the lever. The lever must have enough tension to leave an imprint on your hand.
5. The closed lever position must be between 1-20 mm in front of the fork leg.
6. If the lever does not have enough tension, or has too much tension when closed at the recommended position (1-20 mm in front of the fork), see the next section for adjustment instructions.
7. Compress the fork a couple of times to ensure that the lower leg has settled into its low-friction point.
8. Tighten the pinch bolt on the drive side dropout to 5.1 Nm (45 in-lb) torque.

IMPORTANT: You will only need to tighten the pinch bolt during your first wheel installation. After tightening the pinch bolt, you may remove the QR axle and replace it without loosening or retightening the pinch bolt. If you are changing wheels or hubs, it is likely that the pinch bolt will need to be adjusted by following these installation instructions starting at step 1.

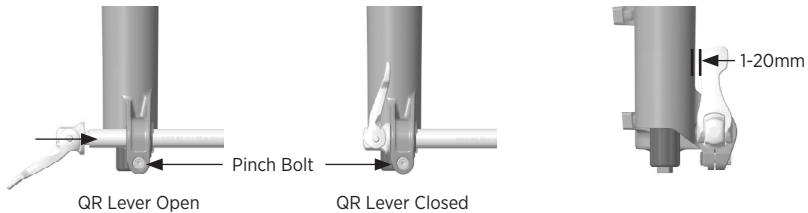

ADJUST THE QUICK RELEASE

1. Note which direction the axle lever needs to turn to achieve proper orientation.
2. Open the axle lever in the fork.
3. While holding the QR lever open and stationary so it cannot rotate, use a 4 mm hex wrench in the center of the end of the axle to adjust the lever position. With the 4 mm adjuster set properly, you should start to feel tension in the axle when the QR lever is 90 degrees before full closure in the vertical position.
4. Repeat the axle installation instructions to verify proper installation and adjustment.

WARNING: Use hand pressure only. Never use any tool to tighten the 15QR levers onto the lower legs. Over-tightening the levers can damage the axle or fork dropouts, leading to a sudden failure with one or more of these components, resulting in **SERIOUS INJURY OR DEATH**.

WARNING: Failure to secure the axle properly can cause the wheel to become detached from the bicycle, resulting in **SERIOUS INJURY OR DEATH**.



KABOLT^X INSTALLATION

IMPORTANT: The Kabolt^X is only compatible with the 2021 36 and 38 forks.

1. Loosen the pinch bolt, then install the front wheel into the fork dropouts. Slide the Kabolt^X axle through the drive side dropout and hub.
2. Use a 6 mm hex wrench to torque the Kabolt^X axle clockwise to the torque specification that is etched on the head of the Kabolt.
3. Compress the fork a couple of times to ensure that the lower leg has settled into its low-friction point.
4. Tighten the pinch bolt on the drive side dropout to 5.1 Nm (45 in-lb) torque.

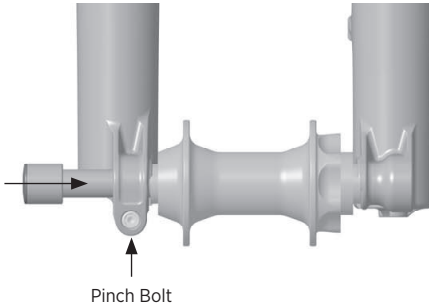

AIR RELEASE BUTTON/ LOWER LEG BLEEDERS

The Air Release Button at the rear of each fork leg allows for built up air pressure to be released for optimal performance. With the fork in the upright position, hold each button for 5-10 seconds.

IMPORTANT: You may notice some bath oil may come out of the bleeders during actuation, this is normal.

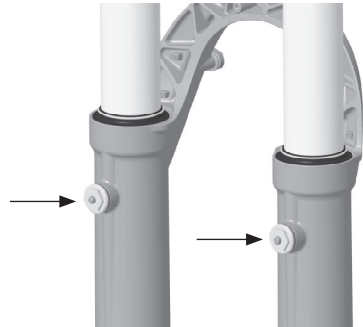

MOUNTING DISC BRAKES

The 38 fork uses 180 mm post mounts that allow you to bolt your caliper directly to the fork and utilize a 180 mm rotor.

If your current 180 mm brake setup came with bolts and a caliper spacer, you may need to source shorter bolts as you will not need a caliper spacer when using a 180 mm rotor.

If using a 203-230 mm rotor, you will need to source the appropriate caliper spacer and bolts. Contact the brake manufacturer for further information.

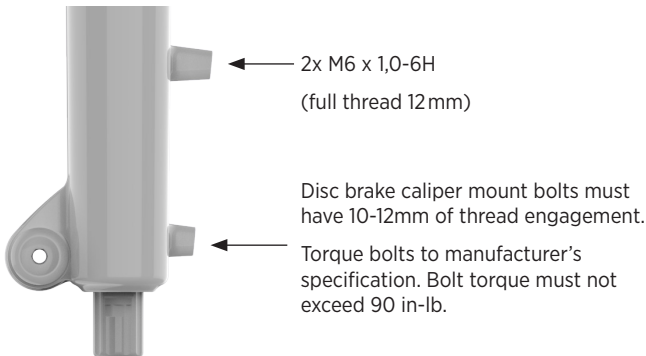

WARNING: Follow your brake manufacturer's installation instructions for proper installation and adjustment of the brake system. Failure to properly install and adjust your brakes can lead to a loss of control of the bicycle which can result in SEVERE INJURY OR DEATH.



ADDITIONAL TUNING OPTIONS

CLIP-ON VOLUME SPACERS

Changing volume spacers in the 38 FLOAT fork is an easy internal adjustment that allows you to change the amount of mid stroke and bottom out resistance.

If you have set your sag correctly and are using full travel (bottoming out) too easily, then you could install one or more spacers to increase bottom out resistance.

If you have set your sag correctly and are not using full travel, then you could remove the spacer to decrease bottom out resistance.

Installation procedure and tuning options are available online at:

ridefox.com/ownersmanuals

| 38 FLOAT Volume Spacer Configurations | | |
|---------------------------------------|----------------------------------|---------------------|
| Travel | Volume Spacers Factory Installed | *Max Volume Spacers |
| 180 mm | 1 | 4 |
| 170 mm | 2 | 5 |
| 160 mm | 3 | 6 |
| 150 mm | 4 | 6 |

| 38 FLOAT E-Bike+ Volume Spacer Configurations | | |
|---|----------------------------------|---------------------|
| Travel | Volume Spacers Factory Installed | *Max Volume Spacers |
| 180 mm | 2 | 4 |
| 170 mm | 3 | 5 |
| 160 mm | 4 | 6 |
| 150 mm | 5 | 6 |

TYPICAL AIR SPRING CURVES

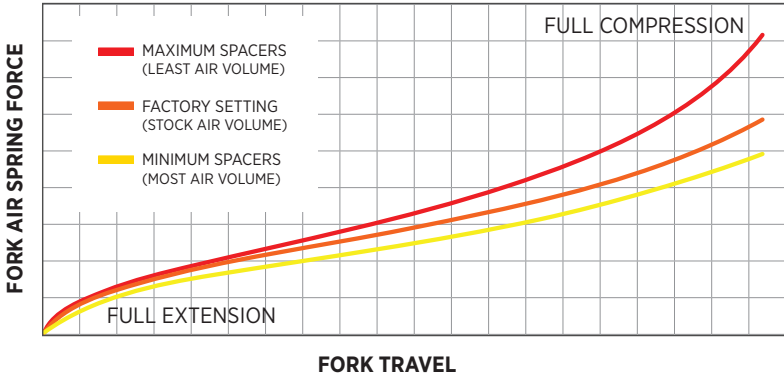

SEE ADDITIONAL INFORMATION AND VIDEOS:

38 FLOAT ridefox.com/38setup

FOX FACTORY



#RIDEFOX RIDEFOX.COM

©FOX FACTORY, INC. 2020 // 1.800.FOX.SHOX
915 DISC DRIVE SCOTTS VALLEY, CA 95066 USA
TEL: 831.768.1100
605-00-247 REV A